

PARALLEL AUXILIARY FRAMING FINISHING CLIP

Modified:08/02/2023

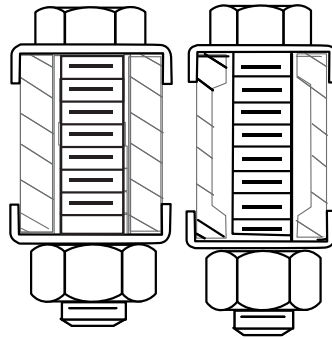
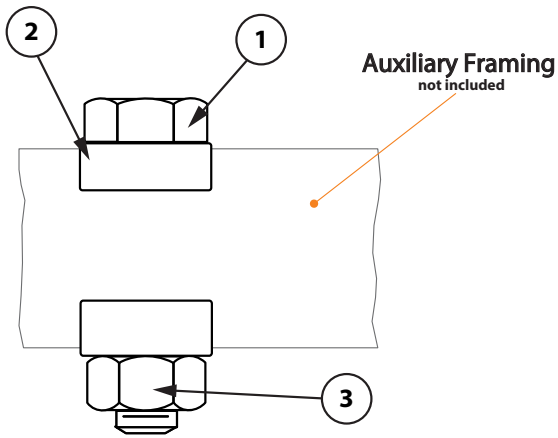

Bar

Channel

Ordering Table

Part Number	Aux	Bolt Size
0010280010	Bar	1/2-13
0010280110	Channel	1/2-13
2204150010	Channel	5/8-11

Stock List

Item	QTY	Description
1	2	HHCS
2	2	Clip
3	1	Nut

Notes:

- Finish is zinc plated and gold chromate.
- Not included; refer to 001021 or 001022.