

THE INFORMATION CONTAINED IN THIS DRAWING IS THE SOLE PROPERTY OF ELECTRO MECHANICAL INDUSTRIES, INC. ANY REPRODUCTION IN PART OR WHOLE WITHOUT THE WRITTEN PERMISSION OF ELECTRO MECHANICAL IND., IS PROHIBITED.

REVISIONS					
REV.	DCN #	DESCRIPTION	DATE	BY	APPROVED
7	01092	UPDATED DUE TO LOWER LEVEL CHANGES TO STRINGERS AND TREAD WELDMENT.	03/23/2022	JTR	JPB

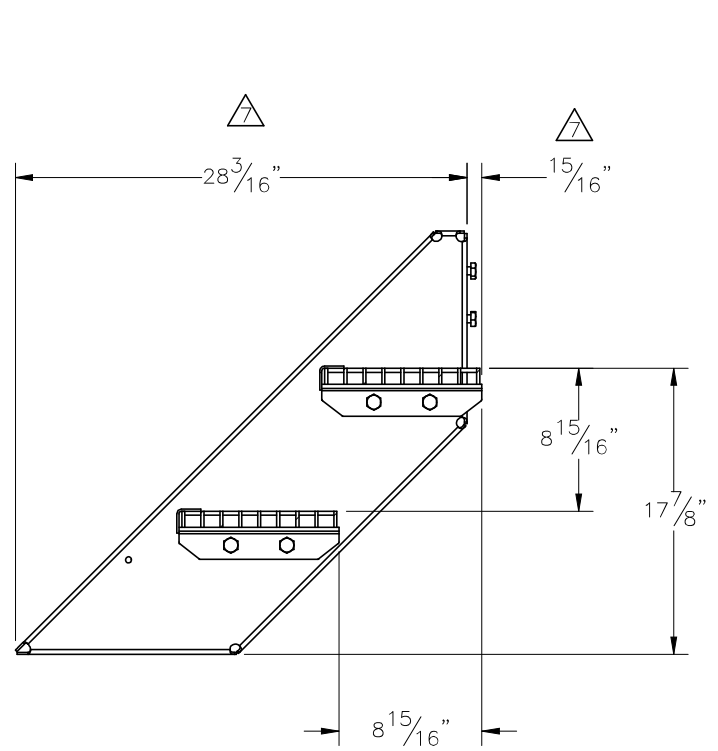

SECTION A-A

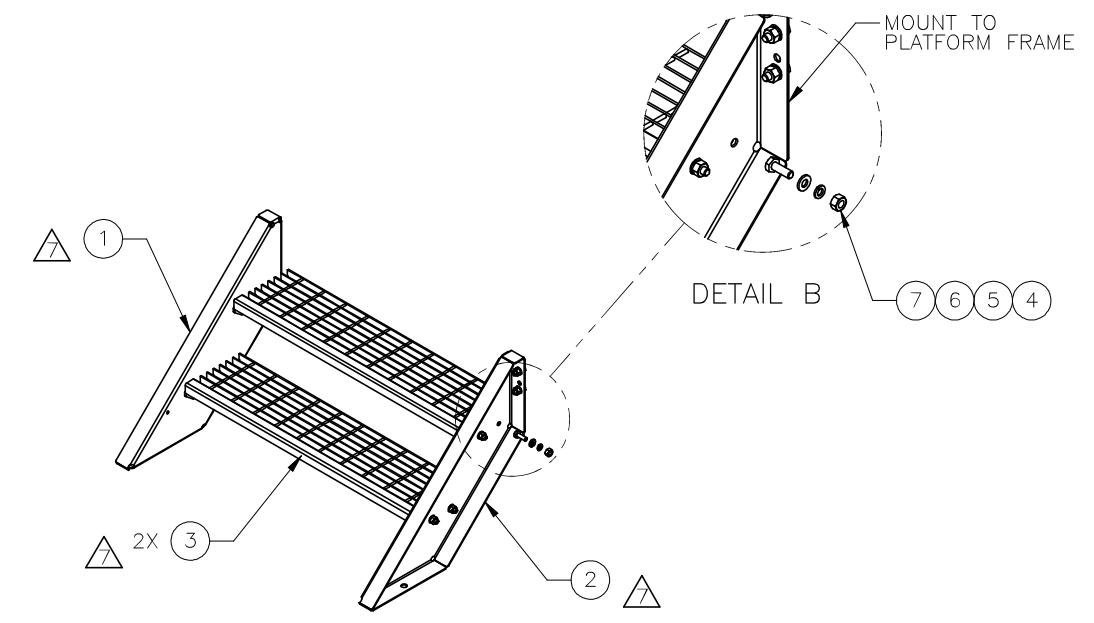
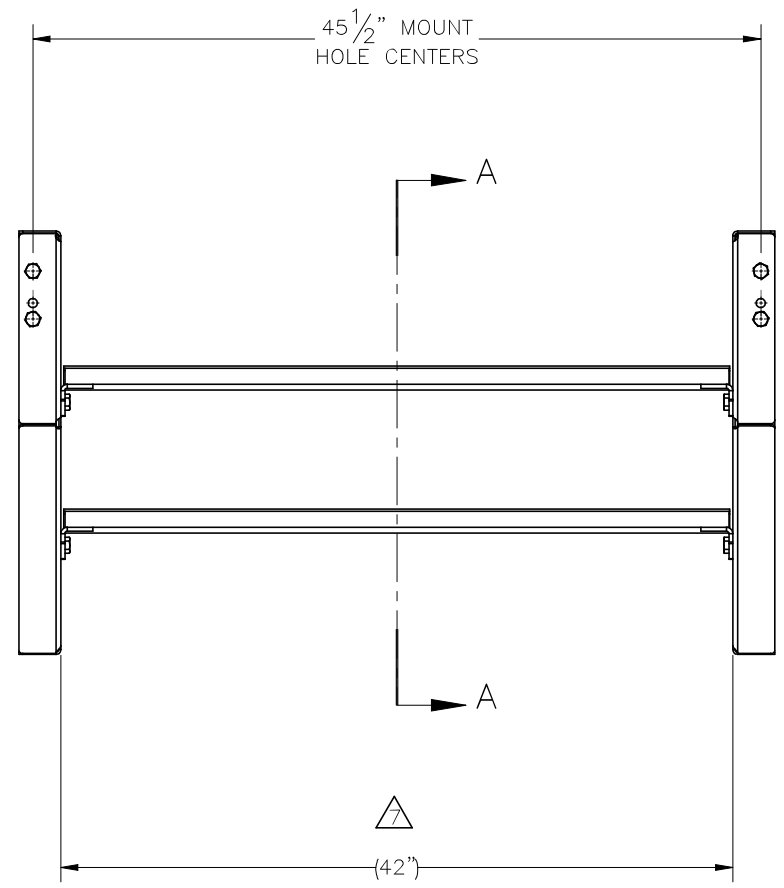

ITEM NO.	QTY REQD	PART NUMBER	DESCRIPTION	LENGTH	WEIGHT
1	1	P-004-290	LEFT STRINGER, FORMED, 2 STEP	36 15/16"	19.1
2	1	P-004-291	RIGHT STRINGER, FORMED, 2 STEP	36 15/16"	19.1
3	2	W-001-864	42" WD, STAIR TREAD WELDMENT		29.82
4	12	002-0BG-0010	HHB, .500-13 X 1.50 LG., PT X 1.00, A325, HDG	1.50	0.14
5	12	002-0FW-G002	FW, .50, F436, HDG		0.02
6	12	002-0LW-G002	WASHER, SPLIT LOCK, .500", GALV		0.01
7	12	002-0NG-0010	NUT, HEX, .500-13UNC, GR 2H, GALV		0.06

SURFACE FINISH <input checked="" type="checkbox"/> UNLESS OTHERWISE SPECIFIED		UNLESS OTHERWISE SPECIFIED DIMENSIONS ARE IN INCHES		APPROVALS		DATE		ELECTRO MECHANICAL INDUSTRIES, INC. 11230 NEESEHAW DRIVE HOUSTON, TEXAS 77065 1-800-453-0050	
MATERIAL SEE PARTS LIST		TOLERANCES .0 ± .06 .00 ± .015 .000 ± .005 FRACTIONS ± 1/16 ANGLES ± .25° HOLES: DRILLED OR PUNCHED ± 1/32 BURNED ± 1/32		DRAWN AJD 9/26/2014		DATE 9/26/2014			
THIRD ANGLE PROJECTION		NEXT ASSY		CHECKER C. SANCHEZ 9/29/2014		ENGINEER C. SANCHEZ 9/29/2014		SIZE B	
APPLICATIONS		USED ON		PRODUCTION J.C. 9/29/2014		DRAWING NO. 450-000-0113			
				SCALE: 1:12		WEIGHT: 100.7 lbs.		SHEET 1 OF 1	