

Cable Horn - Rung Mounted

- Designed as a separator between cables in the runway.
- Grounding lugs included on retainer clip for quick and easy grounding.
- For use with SB17 and SB17T Series runway only.
- Includes: (1) straight cable horn and (1) runway rung retainer clip.
- Material: cable horn - ASTM A510
retainer clip - ASTM A607 Grade 50
- Finish___: Yellow Zinc (YZ) or
Black Zinc (BZ)

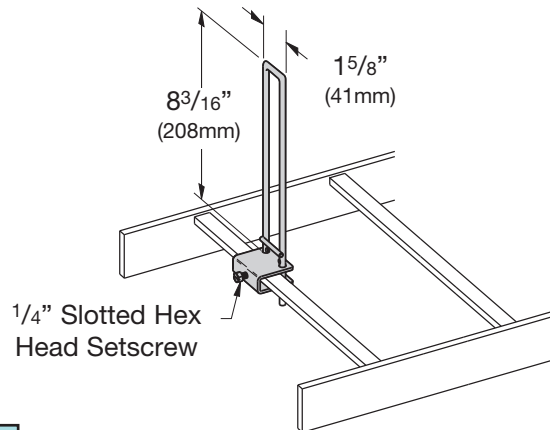

Part Number	Weight	
	Lbs.	(kg)
SB1328___	.67	(0.30)

Overhead Power Cable Support

- Designed as a stringer extension to help retain cables in the runway.
- Includes a upper compartment for additional cabling space.
- Grounding lugs included on retainer clip for quick and easy grounding.
- Includes: (1) straight cable horn with bracket and (1) runway stringer retainer clip.
- Material: cable horn - ASTM A510
retainer clip - ASTM A607 Grade 50
- Finish___: Yellow Zinc (YZ) or
Black Zinc (BZ)

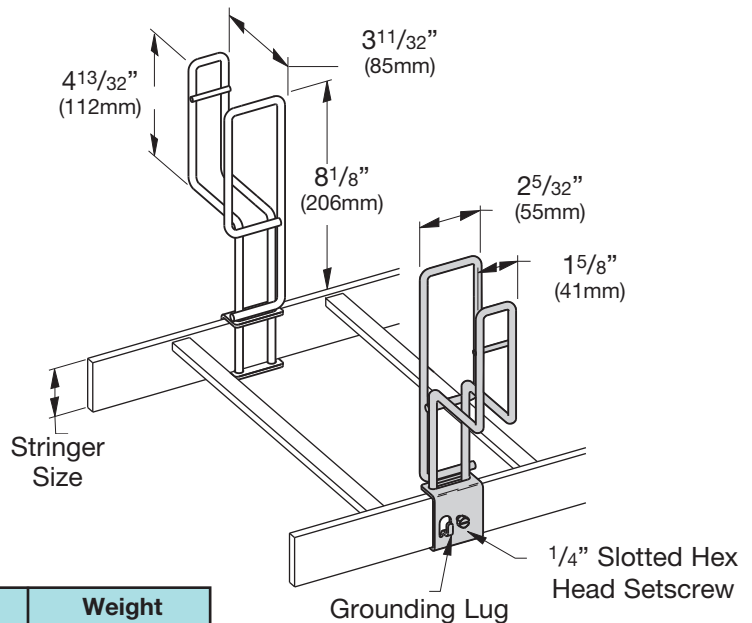

Part Number	Stringer Size		Weight	
	In.	(mm)	Lbs.	(kg)
SB1341 1/2___	3/8" x 1 1/2"	(9 x 38)	.77	(0.35)