

REV	ECO	DESCRIPTION	DATE	BY
-----	-----	-------------	------	----

NOTES: (UNLESS OTHERWISE SPECIFIED.)

1. DIMENSION ARE IN INCHES [CENTIMETERS].

2. DIMENSIONS ARE FOR REFERENCE ONLY.

③ DUSTOMER PART NUMBER MOLD INTO THIS SURFACE.

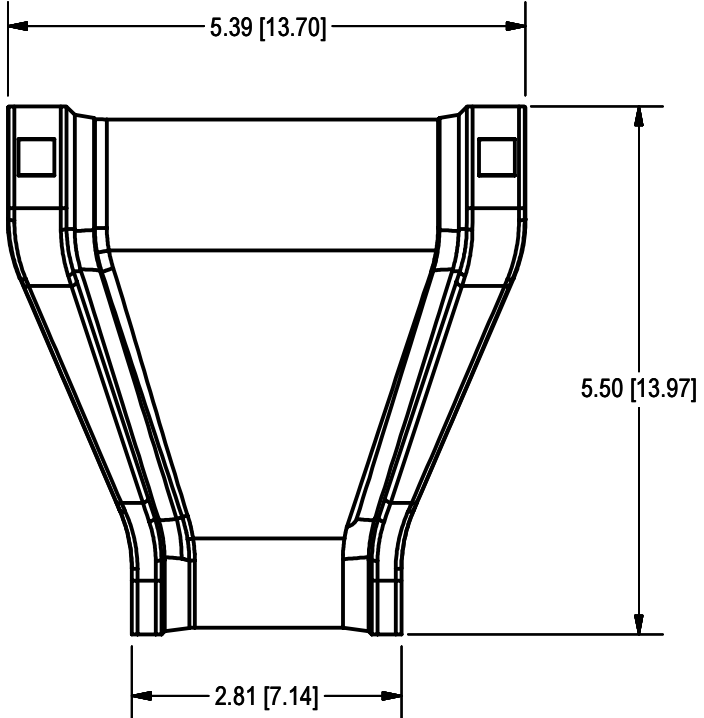

TOP VIEW

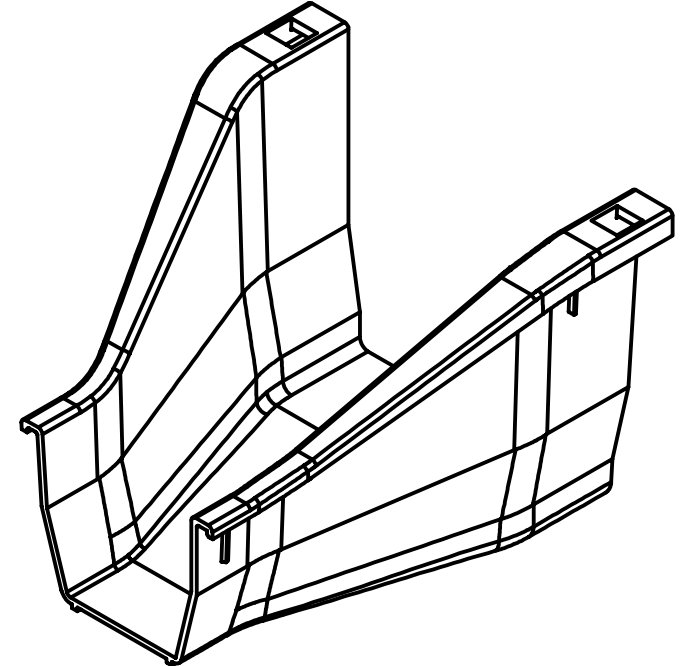

ISOMETRIC VIEW

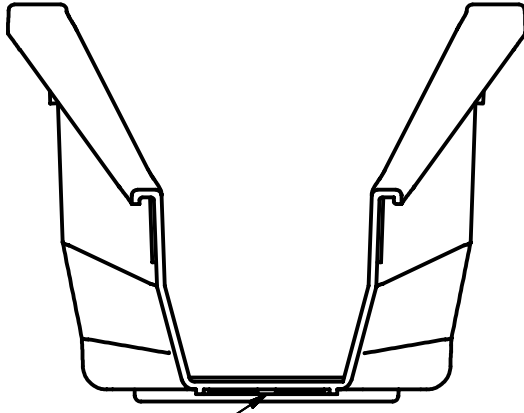

FRONT VIEW

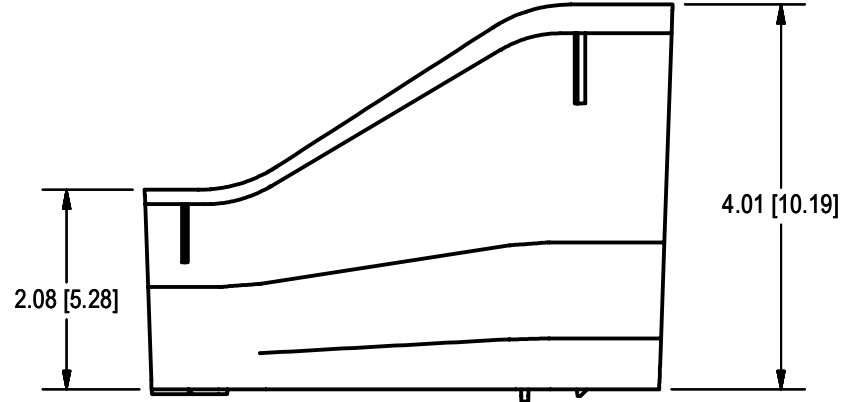

SIDE VIEW

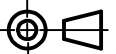
DESIGNED BY S. GLASER	DATE 6/7/2000	 N 2111 Molter Road PO Box 665 Liberty Lake, Washington 99019 (509) 926-6000
DRAWN BY T. TURPIN	DATE 1/24/2001	
<b>NOT FOR REPRODUCTION COPYRIGHT: 2000</b> This document contains proprietary information that is property of TELECT, INC., Spokane, Washington. It is intended for the exclusive use of our customer for information, installation, and/or service. The recipient agrees not to reproduce or copy this document or its contents in whole or in part without prior written permission from TELECT, INC. This document must be returned promptly if no longer needed or upon written request from TELECT, INC.		TITLE CUSTOMER DRAWING TRAX (4) 4" - 2" REDUCER
DRAWING NO 027-2000-4050		SHEET SIZE B A
 PROJECT 4165	SCALE 0.50 : 1.0	SHEET 1 OF 1
		REV 0