

J-BOLT KIT

Modified:06/26/2014

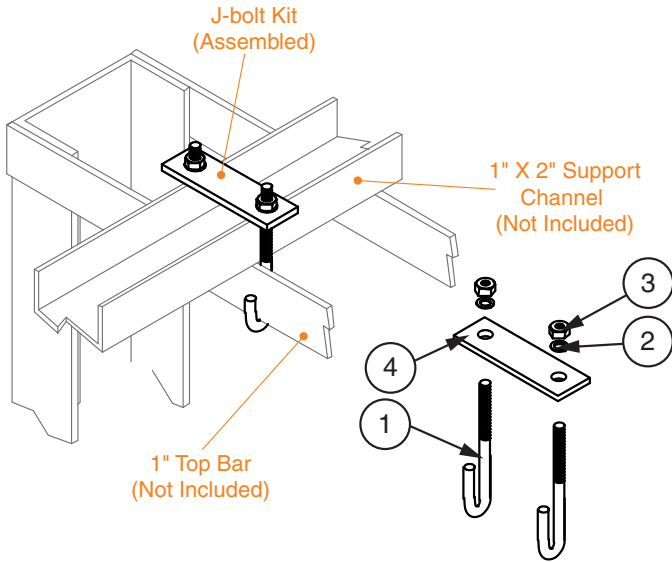

Ordering Table

Part Number	J-Bolt Length
21256000xx	2-3/4"
21765000xx	1-3/4"

Stock List

Item	QTY	Description
1	2	5/16" J-Bolt
2	2	5/16" Lock Washer
3	2	5/16-18 Hex Nut
4	1	Mounting Plate

Notes:

- Finish is zinc plated and gold chromate, finish code 10.