

PARALLEL AUXILIARY FRAMING CHANNEL, 2" X 9/16" X 3/16"

Modified:05/17/2022

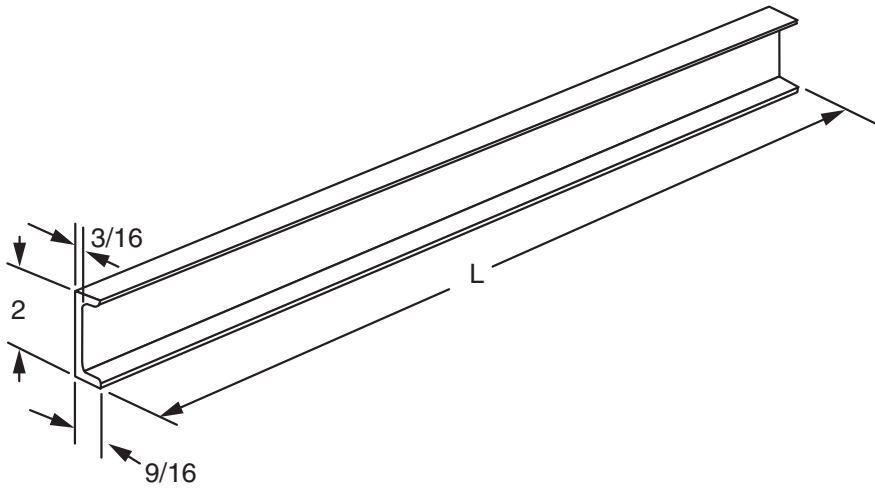

Ordering Table

Part Number	Length
00102201xx	2'
00102202xx	4'
00102203xx	6'
00102204xx	8'
00102205xx	10'
00102206xx	12'
00102210xx	20'

Notes:

- XX = finish code; standard finish, XX = 30.
- Material: hot rolled steel.