

# 1805ZVH 1806AVH Assembly



## Product Number

00180518

## Design Features

- Materials
  - Frame  
Gray Iron (CL35B)
  - Cover  
Gray Iron (CL35B)

- Design Load  
Heavy Duty
- Open Area  
n/a
- Coating  
Undipped
- √ Designates Machined Surface

## Certification

- ASTM A48
- 
- Country of Origin: USA

## Major Components

00180511  
00180625

## Drawing Revision

03/27/2007 Designer: GAD  
03/17/2014 Revised By: DVD

## Disclaimer

Weights (lbs./kg) dimensions (inches/mm) and drawings provided for your guidance. We reserve the right to modify specifications without prior notice.

CONFIDENTIAL: This drawing is the property of EJ GROUP, Inc., and embodies confidential information, registered marks, patents, trade secret information, and/or know how that is the property of EJ GROUP, Inc. Copyright © 2012 EJ GROUP, Inc. All rights reserved.

## Contact

800 626 4653  
ejco.com

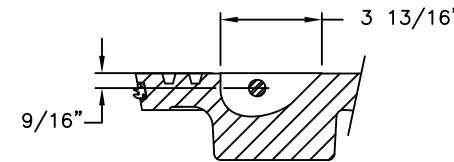
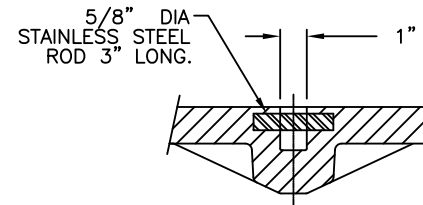
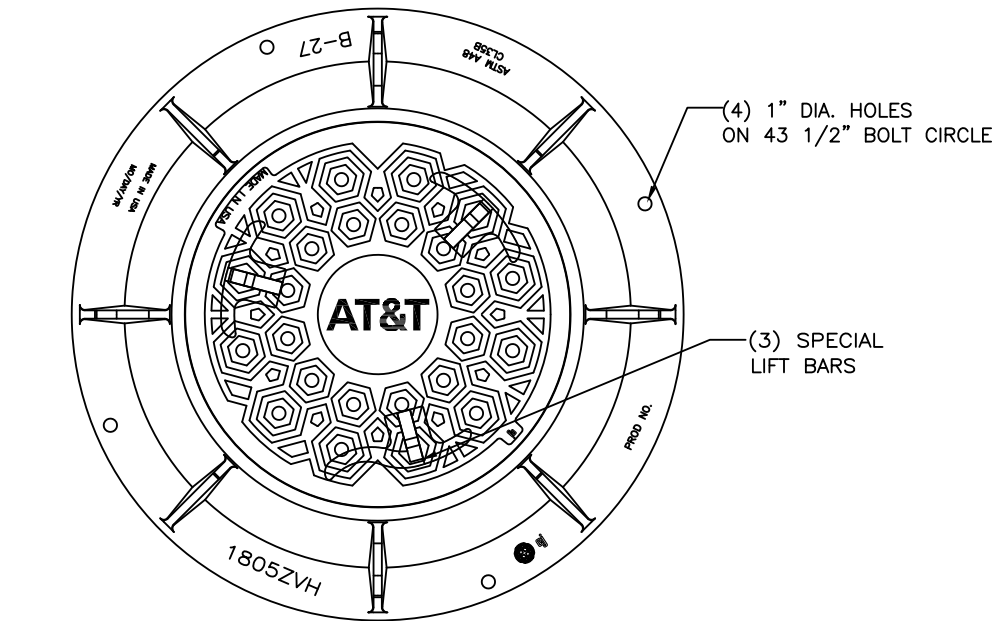

PICKBAR DETAIL

GROOVE DETAIL

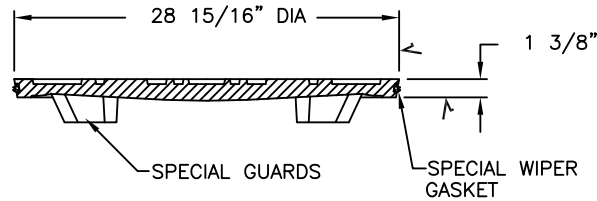

COVER SECTION

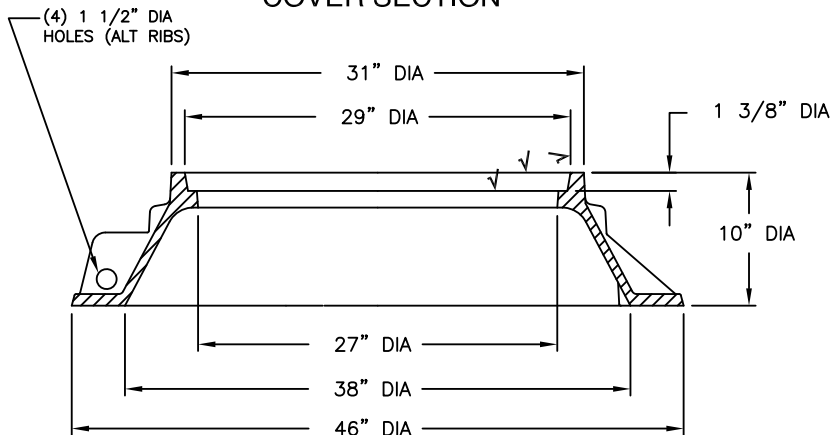

FRAME SECTION

NOTE: COMPONENT ITEM. NOT ASSEMBLED.  
PARTS ARE SHIPPED LOOSE.  
ASSEMBLED ON JOB SITE.

CAST NO. IS 180625  
FINISHED NO. IS 180626  
(WITH GASKET)